

5HH-D Series

Horizontal Conn Rod Diamond Ream Systems

Standard Features

- Modular design with industry proven components
- Horizontal spindle arrangement
- Electronic stroke control
- PLC controlled machine functions
- User-friendly operator interface
- Adjustable stroke and feed position
- Fault diagnostic software
- Bend and twist correction

Description

The 5HH-D Series horizontal diamond ream machines quickly and accurately finish the pin and crankshaft bores of connecting rods and similar parts. The capability and global reputation of these machines have made them preferred equipment for high-volume production of connecting rods in facilities around the world.

Ream tools are well suited for generating accurate size and surface finish, in addition to correcting cylindrical form like roundness, straightness and taper. The tools are designed to allow a set of diamond abrasive inserts to quickly pass through a cylindrical form in a single pass process. The abrasive inserts remain at a fixed diameter throughout the process while only removing material that is diametrically smaller than the setting of the tool inserts. This technique provides advantages over conventional honing, since less machining stock is required to achieve an equivalent result. In addition, ream tools can be used with water based coolants which provide ergonomic and environmental advantages.

The 5HH-D Series diamond ream machines are arranged with an in-line transfer configuration in either a single or double pitch transfer. Stock is normally removed in three or more stages, with the ream tool at each stage removing a portion of the overall machining stock.

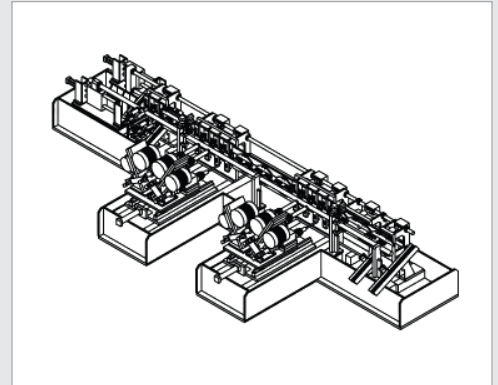

All 5HH-D Series ream machine include as standard equipment, a PLC based programmable controller for monitoring and controlling various machine motions and process parameters throughout the machining operation. Also included as standard equipment is a crank & pin bore go-no/go type pre-gauge system with reject unit, and a crank & pin bore air/electronic post process gauge system with reject unit.

Options include coolant filtration and refrigeration system, SPC process control software and modifications to encompass customer specified components. KENRIE can also further enhance your 5HH Series diamond ream machine by integrating a variety of production automation like marking systems or load/unload automation as part of the basic machine design.

All 5HH-D Series ream machines can be adapted to process different connecting rod configurations by changing the part contact details, ream tools and gauge probes.

Guide Specifications

Efficiency Standards for a Typical 5HH-D Series Connecting Rod Ream Process

| Characteristic | CPK | Rbar | St Dev | Tolerance |
|-----------------------|------|-------|--------|------------|
| Crankbore size Ø | 5.48 | 1.2µm | 0.05µm | ± 10.0µm |
| Crankbore roundness O | 7.11 | 1.0µm | 0.04µm | 10.0µm max |
| Crankbore taper // | 4.37 | 1.5µm | 0.06µm | 10.0µm max |
| Bend | 7.60 | 0.4µm | 2.00µm | 76.0µm max |
| Twist | 3.63 | 1.8µm | 0.80µm | 10.0µm max |
| Pinbore size Ø | 6.87 | 2.0µm | 0.08µm | ± 20.0µm |
| Pinbore roundness O | 8.09 | 1.6µm | 0.06µm | 20.0µm max |
| Pinbore taper // | 6.45 | 2.1µm | 0.09µm | 20.0µm max |

| Machine type | Production rate | Total cycle time | Transfer type | # of spindles |
|--------------|-----------------|------------------|---------------|---------------|
| 5HH-D8 | 600 PPH | 6.0 seconds | Single pitch | (8) total |
| 5HH-D16 | 1100 PPH | 6.5 seconds | Double pitch | (16) total |